

POMEAS 1" FA Lens Series:
8MP: PMS-35LC8M



Product Description

- ◆ Support 8MP 1" camera.
- ◆ Focus locking screw and Iris locking screw.
- ◆ Low distortion imaging.
- ◆ Compact structure design, excellent optical performance.

Applications

Widely used in machine vision production automation and other industries.

PMS-35LC8M Product Parameters

Code		PMS-35LC8M
Max. Sensor Size		1"(16mm)
Corresponding Wavelength		420~1000nm
Focal Length		35mm
Interface		C-Mount
Iris Range		F2.0-close
FOV(D×H×V)	1"	26.10°×20.83°×15.72°
	1/2"	13.28°×10.65°×7.94°
	1/3"	9.92°×7.92°×6.00°
Object Size	1"	81.10×64.88×48.66mm
	1/2"	40.52×32.42×24.31mm
	1/3"	30.42×24.34×18.25mm
Optical Back Focal Length (in air)		12.96mm
Operation Method	Focus	Manual
	Iris	M-Iris
Distortion Rate	1"	0.28%@y=8mm
	1/2"	0.07%@y=4.0mm
	1/3"	0.04%@y=3.0mm
Imaging Range		0.2m~∞
Filter Size		M30.5×0.5mm
Weight		70.35g
Working Temperature		-20°C ~ +60°C

PMS-35LC8M Product Size

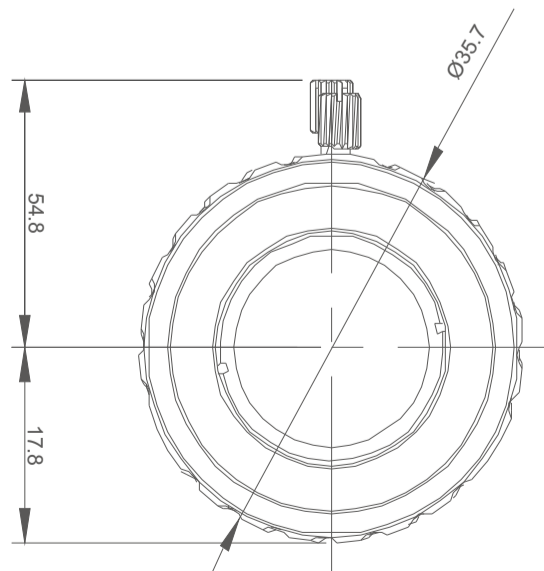
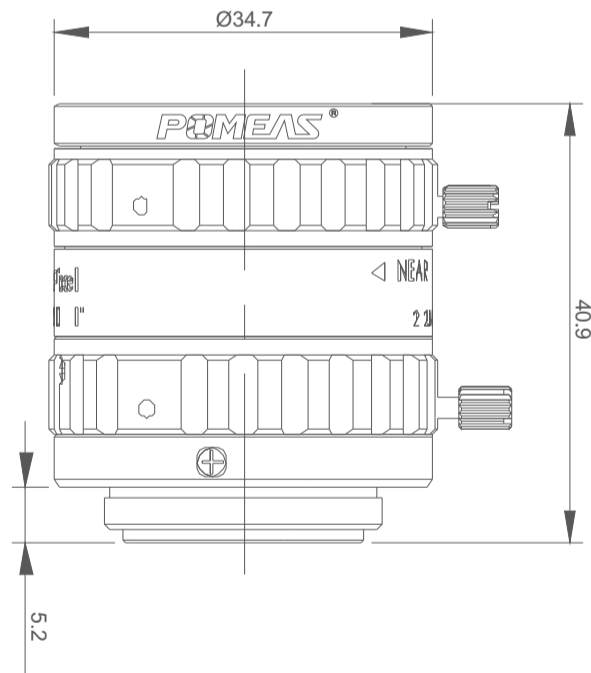

unit: mm

