

**POMEAS 1" FA Lens Series:**

8MP: PMS-50LC8M



**Product Description**

- ◆ Support 8MP 1" camera.
- ◆ Focus locking screw and Iris locking screw.
- ◆ Low distortion imaging.
- ◆ Compact structure design, excellent optical performance.

**Applications**

Widely used in machine vision production automation and other industries.

**PMS-50LC8M Product Parameters**

Code		PMS-50LC8M
Max. Sensor Size		1"(16mm)
Corresponding Wavelength		420~1000nm
Focal Length		50mm
Interface		C-Mount
Iris Range		F2.0-close
FOV(D×H×V)	1"	18.38°×14.70°×10.98°
	1/2"	9.34°×7.42°×5.5°
	1/3"	6.96°×5.53°×4.16°
Object Size	1"	72.50×57.94×43.34mm
	1/2"	36.18×28.76×21.66mm
	1/3"	27.26×21.74×16.34mm
Optical Back Focal Length (in air)		21.35mm
Operation Method	Focus	Manual
	Iris	M-Iris
Distortion Rate	1"	-0.013%@y=8.0mm
	1/2"	0.010%@y=4.0mm
	1/3"	0.04%@y=3.0mm
Imaging Range		0.25m~∞
Filter Size		M37×0.5mm
Weight		105.25g
Working Temperature		-20°C ~ +60°C

**PMS-50LC8M Product Size**

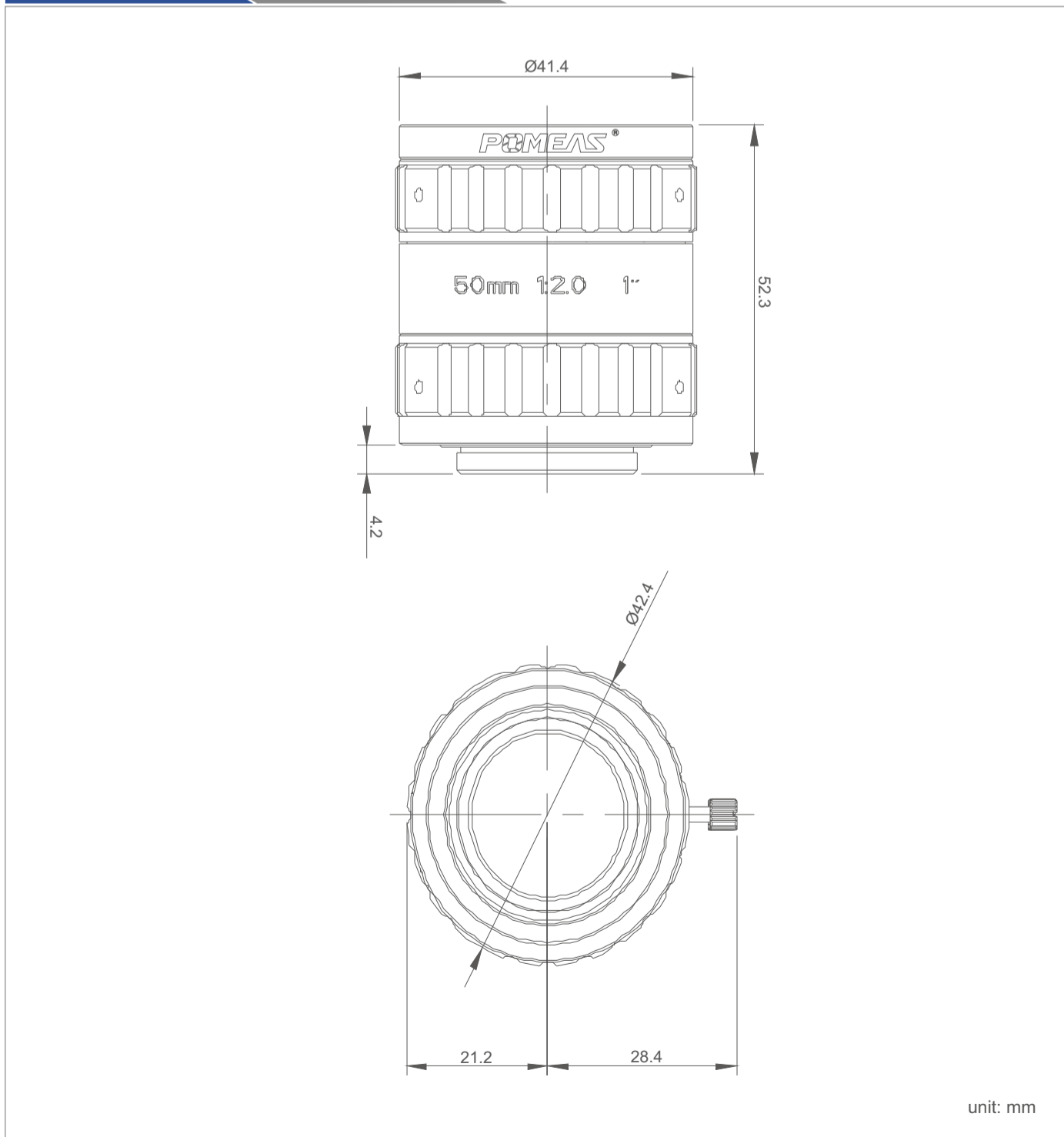

unit: mm

