

APO Laser AF Module

VP-LFS M8000 Series

High Mag. · High Accuracy · High Efficiency

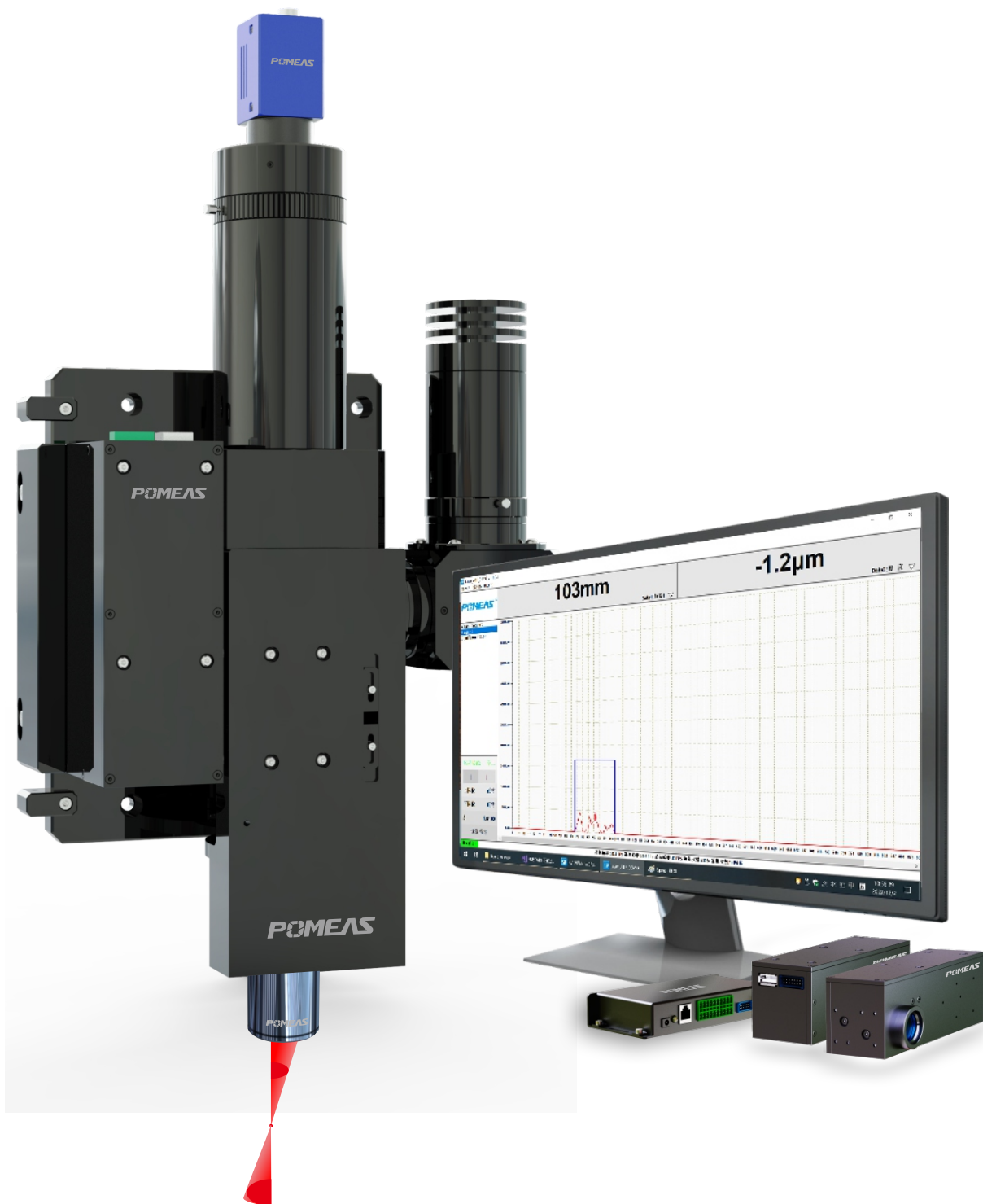

Large field-of-view snapshot customized for high-speed, high-precision microscopy automation

VP-LFS Series Sensor

Product Feature



◆ Compact structure, integrating semiconductor laser, optical system, high-speed signal processing module, laser control, motion control, and software algorithm, the focusing method adopts coaxial focusing mode, which effectively solves the occlusion problem during focusing;

◆ Focusing accuracy μm level, focusing speed up to 6.5kHz level, high focusing accuracy, focusing speed, product performance is stable and reliable, can be widely used in complex applications and environments.

VP-LFS Series Sensor

Static or Dynamic Focus

The combination of laser optics and an integrated microprocessor allows the LFS series of sensors to focus equally on static surfaces and those that are dynamically moving.

High Speed and Accuracy

The internal update rate is 10 kHz and the output rate is up to 6.5 kHz. Automatic adjustments, advanced processing, and onboard algorithms allow LFS Series sensors to maintain this focus, even while moving at high speeds on complex surfaces.

Easy Integration and Implementation

Ease of integration and implementation are key features of LFS. Both analog and digital output variants are available. A number of controller options are also available including those required to interface with many 3rd party stepper, linear and piezo Z motion systems.

Maximized Flexibility

Sensors can operate on many surfaces including unpatterned, patterned, rough and diffuse surfaces. Adapts to a wide range of reflective surfaces by automatically sensing and adjusting the LFS. The sensor is compatible with objective lenses from 2X to 100X.

- ◆ The LFS sensor series can be integrated into customer supplied microscope systems;
- ◆ Several sensor models are available to meet the needs of various applications.
- ◆ It can be widely used in the fields of real-time focusing for microscopic observation, precision laser welding, precision laser cutting, etc.

LFS M8000 SERIES

Pomeas APO Mirror Tube

Maximum 2" lens barrel

LFS Series Sensor

Pomeas APO Objective Lens

Supports 2X~100X objective lenses and universal objective lenses.

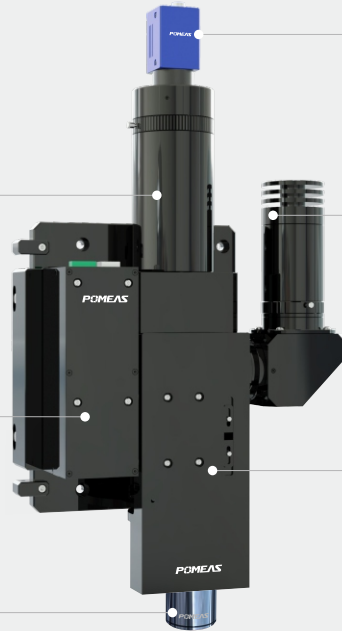

Pomeas Industrial Camera

Supports up to 1.25" CCD camera

Pomeas Coaxial Light Source

Provides single-color or RGB multi-source illumination

Motorized Focus Module

Supports multiple focusing motion modes (screw, piezo)

Sensor Demo Platform

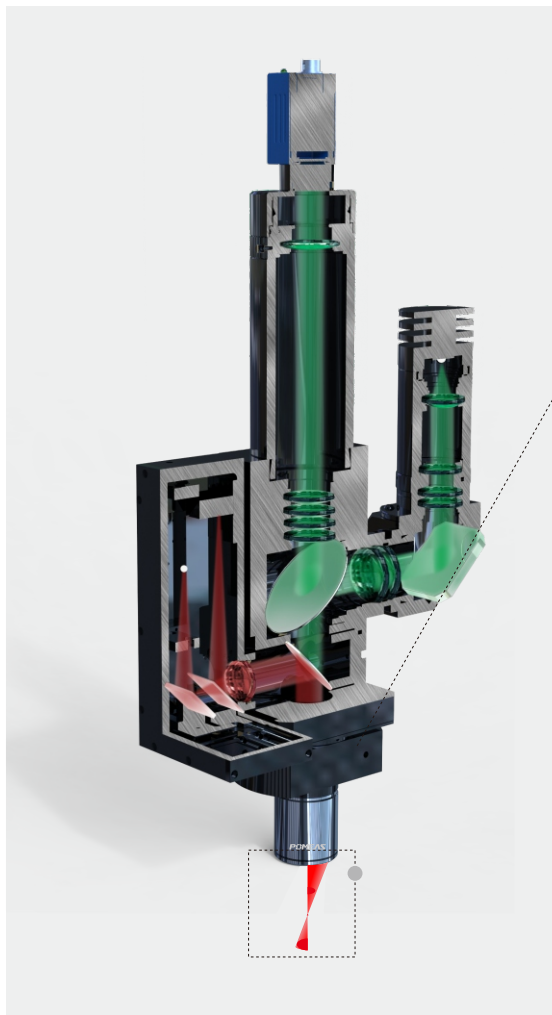

Focusing Principle

Utilizing the optical principle that the point of light will be inverted after passing through the focal point, letting the Sensor determine whether the current Z-axis height is above or below the focal point, and then giving commands to quickly follow the focus in one direction.

Whether the center point is in the middle of the semicircle is used to determine whether the Sensor setup position is accurate or not, and switching is done when the focus changes to reduce Sensor misjudgment.

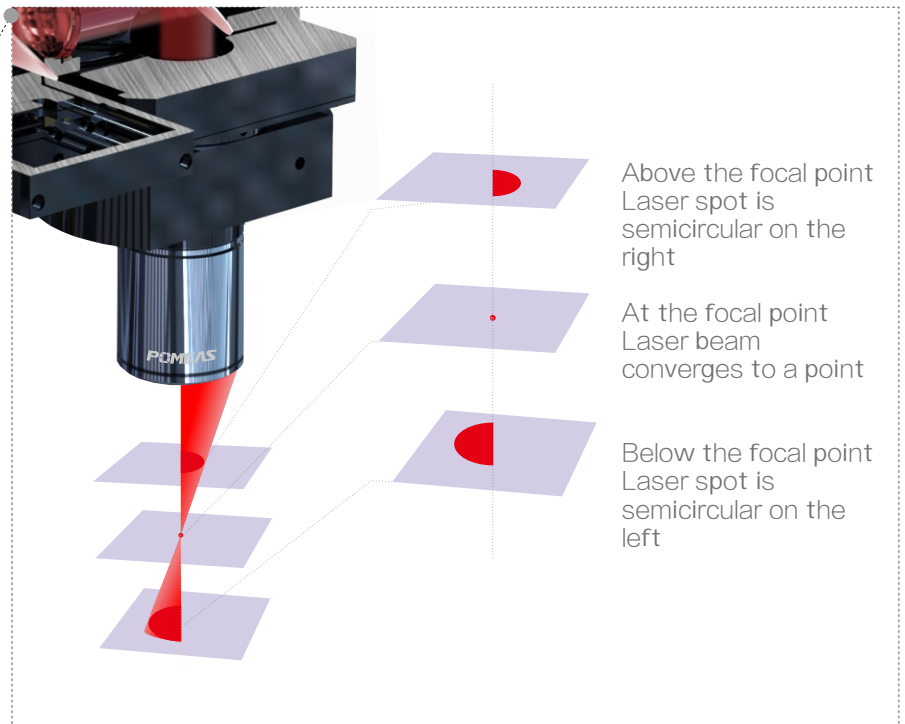

Focus Motion Dedicated Controller Product Introduction



Focus Motion Dedicated Controller

- ◆ Supports A/B two groups of motor drive control
- ◆ Support photoelectric sensor limit for A/B two sets of motors
- ◆ Supports NPN-type and PNP-type limit sensors
- ◆ Support 1 channel high current constant current LED light source: default 3.3V/1A (support 0.75A~1.5A)
- ◆ Supports analog signal output
- ◆ Support RS-232 communication
- ◆ Support control of multi-channel motor movement
- ◆ Supports rotating nose wheels for porous objectives

Focus Motion Dedicated Controller Product Parameter

Power	AC100V±10% 50/60Hz Line length 2M
Voltage	0.5A
Working Temperature	10-50°C
Dimension	W254 x D332 x H75mm
Weight	3.3kg
Option	External Operation Box (PI/O Link Port)
Corresponding Motor	2 phase stepper motor 0.85A/phase (6V)
Control Function	Stepper movement, home return, panel operation
Drive Frequency	Max. 20MHZ
Home return	Mechanical Home, OFF-SET Home
Over Run	Limit Switch
Communication Function	RS-232C/PI/O

Objective Lens Controller Product Introduction

Suitable for universal objective lenses, commonly used 2X, 5X, 10X, 20X objective lenses are applicable;

Can focus on various types of surfaces that are stationary or moving in real time, such as surface focus, layered focus, etc.;

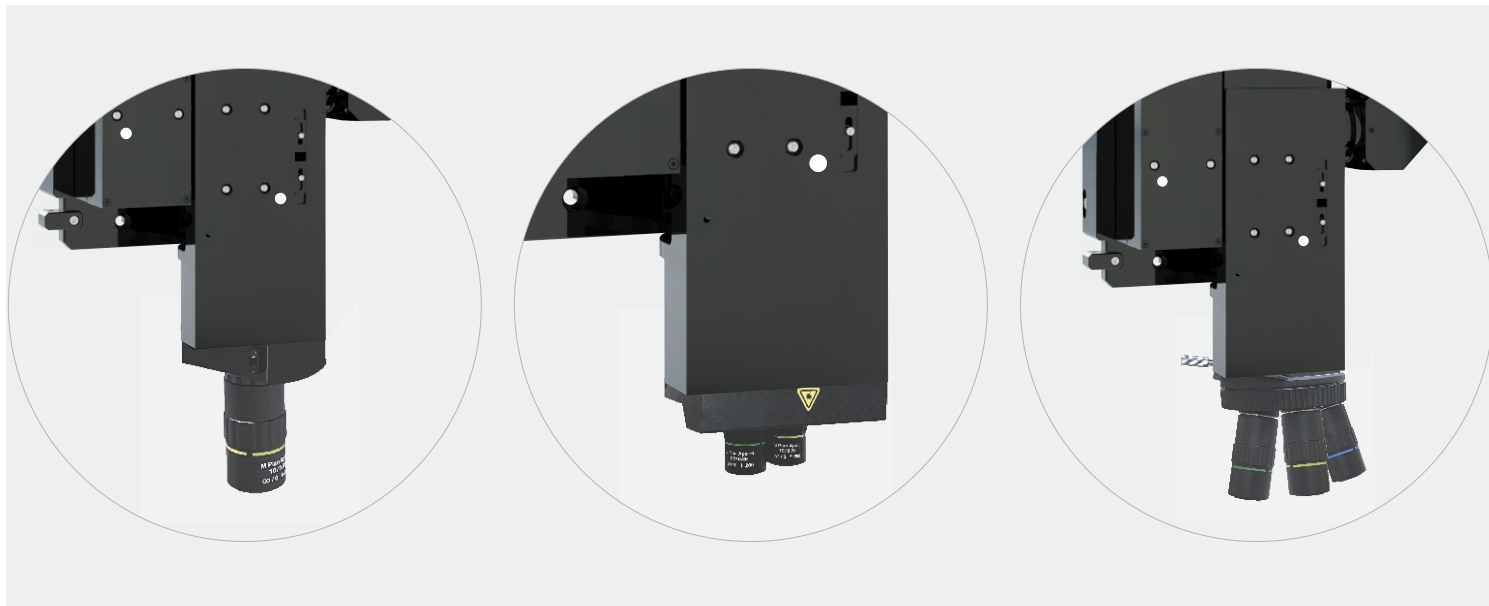

LFS M8000 SERIES

Application Case

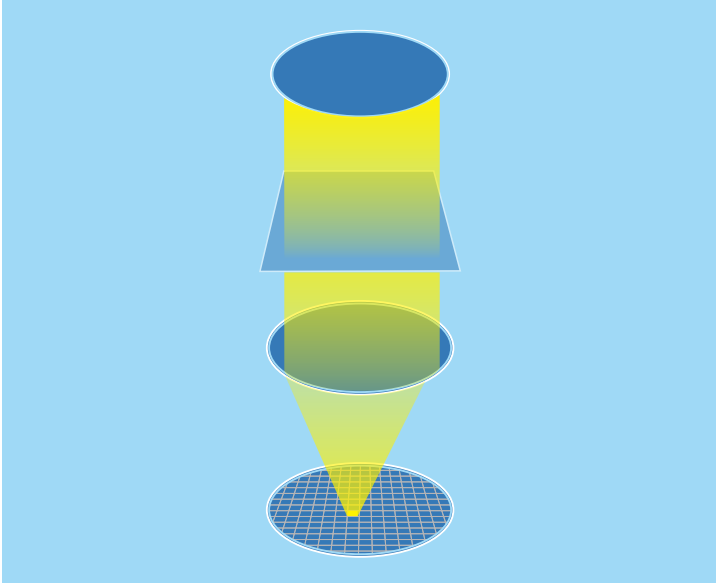

Lithography Guidance and Inspection

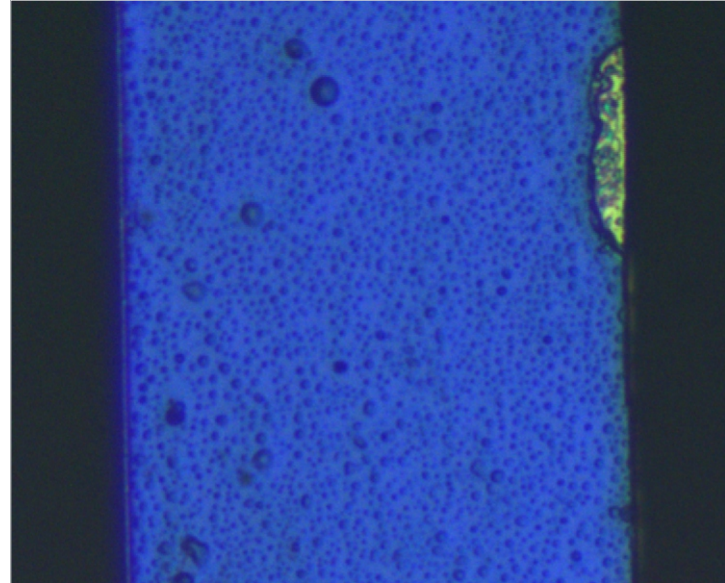

Wafer Substrate (Guidance and Inspection)

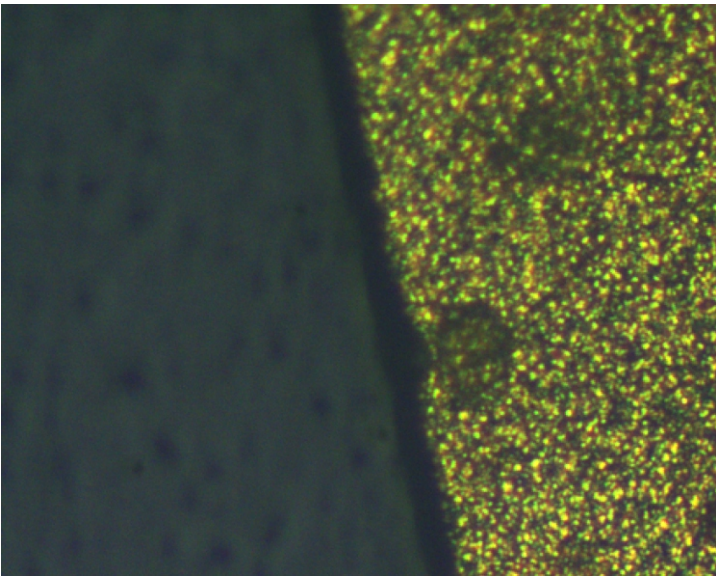

Copper Foil (Guidance and Inspection)

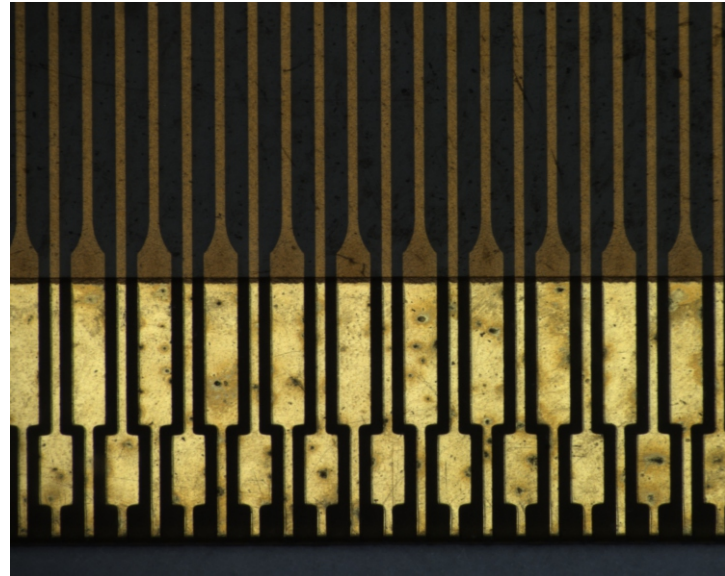

LCD (Guidance and Inspection)

LFS M8000 SERIES

Product Parameter

Item	LFS4		
Optional Wavelength(nm)	650	785	850
Power Output(nw)	650	785	850
Laser Classification	Class III B		
Maximum Focus Distance(mm)	200mm		
Internal Update Rate	20kHz		
Output Data Rate	1.7kHz/6.5kHz		
Structured Light Mode	Single Point		
Sample Reflectance	1%-99%		
Static AF Accuracy	±1/4 objective lens DOF or better		
Moving AF Accuracy	±1/2 objective lens DOF or better		
AF Repeatability	±1/3 objective lens DOF or better		

LFS M8000 SERIES

Product Parameter

Objective lens Mag./NA	Linear Range(μm)
5X/0.14	±500
10X/0.28	±100
20X/0.42	±30
50X/0.55	±20

LFS M8000 SERIES

Motion Control

Z-axis Feature	Miniaturized x High Rigidity Magnetic Floating Linear Ball Guideway+Stepper Motor+Limit Sensor (optional piezo drive)
Optional Z-axis stroke	±10mm/±15mm
Repeat Positioning Accuracy	±0.5μm(Optional piezoelectric drive can reach nanoscale positioning)
Response Speed	20mm/sec、30mm/sec

APO Objective Lens Selection

Product Parameter

Model	Mag. Ratio	N.A.	Working Distance (mm)	Focal Length (mm)	DOF (μm)	Resolution (μm)	Max. FOV
66202	2X	0.055	34.6	100	91	5	40
66205	5X	0.14	45	40	14	2	40
66210	10X	0.28	34	20	3.5	1	40
66220	20X	0.29	30.8	10	3.5	1	28

